

Kim Frankcombe

INSTRUCTION MANUAL  
for  
LACOSTE & ROMBERG, INC.  
MODEL G  
LAND GRAVITY METER

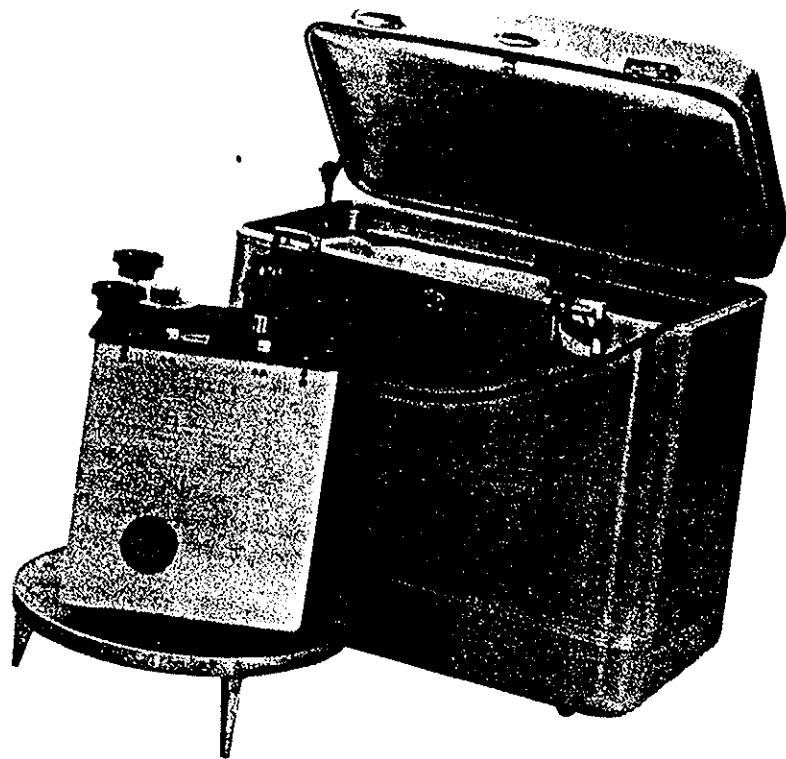

LACOSTE & ROMBERG, INC.  
6606 North Lamar Blvd.  
Austin, Texas 78752  
United States of America

Phone: (512) 453-0821  
Cable Address: LAR

This instruction manual is issued for

Model G Gravity Meter #G- 518 607

Reading Line: 2.80 2.70

Operating Temperature: 52.0 °C 50.5

The LaCoste & Romberg Model G gravity meter and the accessories that are normally supplied with the gravity meter are shown on the following pages. Model G gravity meters have a range of over 7000 milligals, a reading accuracy of  $\pm 0.01$  milligal, and a drift rate of less than 1 milligal per month.

LaCoste & Romberg gravity meters are sealed to eliminate any effect from changes in the atmospheric pressure. As a safety precaution, they are also internally pressure compensated. The sensor is completely demagnetized and then enclosed within a magnetic shield.

The gravity meter, carrying case and battery weigh about 19 pounds. The battery charger and leveling disc weigh an additional 8 pounds.

# MODEL G LAND GRAVITY METER

The LaCoste & Romberg, Inc. Model G gravity meter can be obtained in four variations. The first is the standard gravity meter. The second is the standard gravity meter with electronic readout. The third is the standard gravity meter with variable damping. The fourth has both electronic readout and variable damping. All the Model G gravity meter options can be installed in the large outer box with top leveling knobs. Special order gravity meters can be installed in a small box where the leveling is done at the bottom. The small box can only accommodate the standard gravimeter or one with electronic readout.

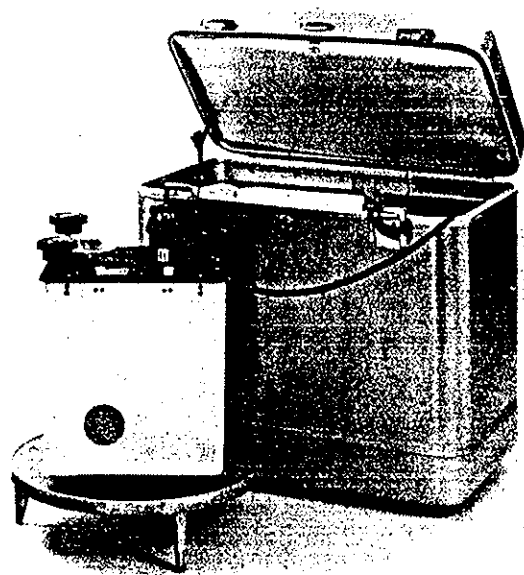

Standard G-Meter with Halliburton Carrying Case and Levelling Disc

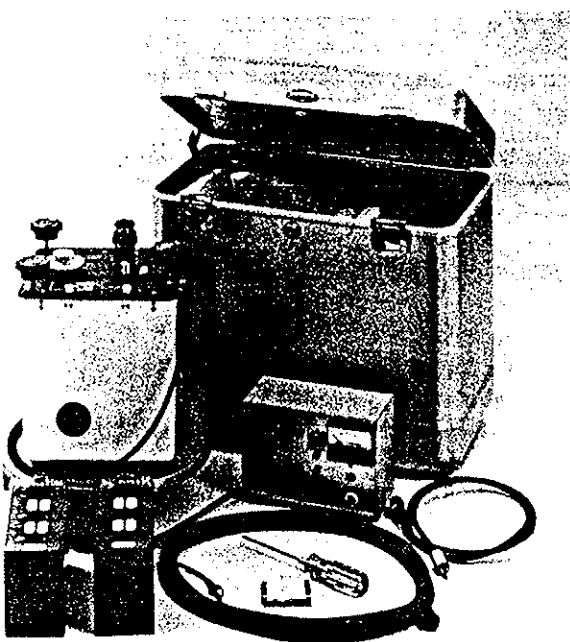

Standard G-Meter with All Accessories  
Normally Supplied

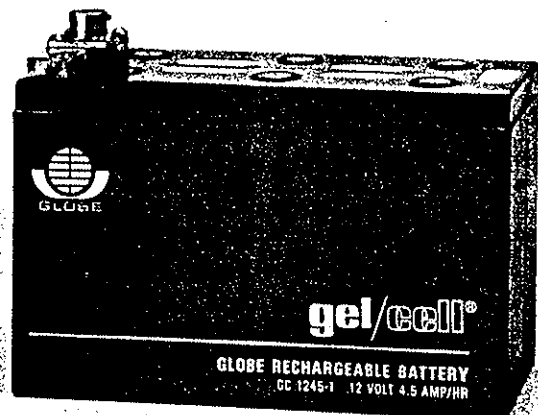

Gel/Cell Rechargeable Battery

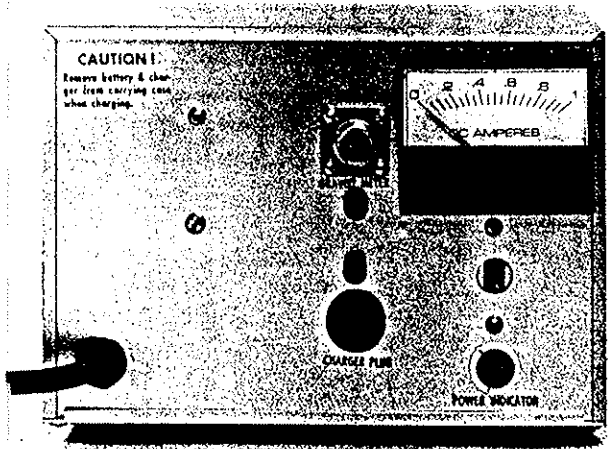

Charger-Eliminator Unit for Gel/Cell Battery

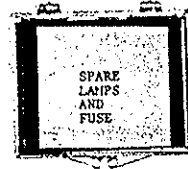

Allen Level Adjusting Wrench  
Spare Reading Lamps  
and Spare Fuse for Charger

### OPERATING INSTRUCTIONS

The gravity meter is shipped off power. Since the LaCoste & Romberg instrument is temperature controlled, the first step is to bring the instrument to its operating temperature. The meter will thermostat at the temperature shown on page 1. Connect the power cord from the meter to:

1. The battery eliminator unit (see section "Battery Eliminator-Battery Charger Unit") OR
2. The battery supplied with the gravity meter OR
3. Any 12-volt power source

The Gel/Cell battery normally supplied with the meter has a capacity of 4.5 ampere-hours. The red tag tied to the battery indicates the state of charge. The battery is normally shipped in a charged state but before it is used, check to make sure that the battery is fully charged before operating the meter from it. Before charging battery read section in this manual concerning the battery.

A cable, referred to as an auxiliary battery cable, is supplied for connecting the meter to a 12-volt d.c. power source other than the battery supplied with the meter. Polarity must be observed when connecting this cable.

The gravity meter should be allowed to stabilize at its operating temperature for at least two hours prior to use.

The following is a general procedure for obtaining a gravity reading:

1. Place the meter on the concave leveling disc furnished with the meter. (If conditions permit, the operator may prefer not to use the disc, but the use of the disc will speed up leveling. Within a survey, the disc must consistently be used or not used.)
2. Turn on the lights for the levels and optical system using the switch located on top of the gravity meter.
3. Level the meter.

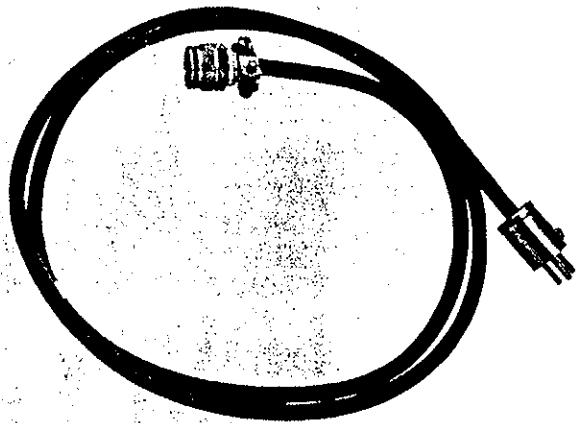

Battery Charger Cable

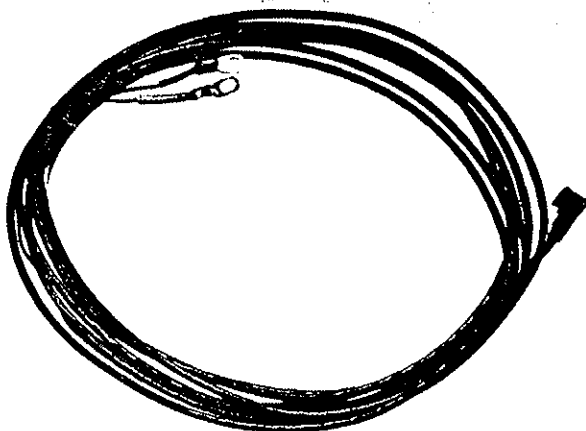

Auxiliary Battery Cable

4. Obtain the difference in the original Counter-dial reading and the counter reading chosen from Table 1.

$$2654.36 - 2600 = 54.36$$

5. Multiply this difference (54.36) by the interval factor given in the table for a counter reading of 2600.

$$54.36 \times 1.05239 = 57.21$$

6. Add the above product to the milligal value. The sum thus obtained is the milligal value for the gravity station.

$$2731.10 + 57.21 = 2788.31$$

Example: Table 1

COUNTER READING	VALUE IN MILLIGALS	FACTOR FOR INTERVAL
2500	2625.88	1.05218
2600	2731.10	1.05239
2700	2836.34	1.05262

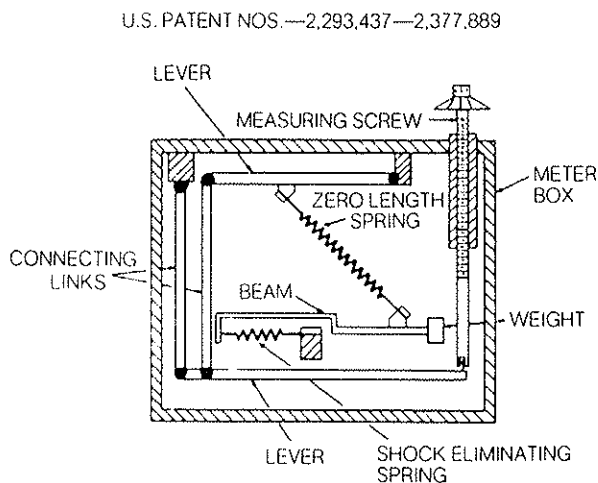

Principle of Operation

### PRINCIPLE OF OPERATION OF LACOSTE AND ROMBERG GRAVITY METER

A simplified diagram of the basic LaCoste and Romberg gravity meter is shown above. The gravity response system consists of a weight on the end of a horizontal beam supported by a zero-length spring as shown in the diagram. The shock eliminating springs form a floating pivot, thus eliminating any friction in the moving system. Since the gravity response system is completely suspended by springs, it will withstand nearly any shock that will not damage the housing which supports it.

The lever system and measuring screw shown in the diagram are accurately calibrated over their entire range. Calibration factors depend only on the quality of the measuring screw and the level system, not upon any type of weak auxiliary springs. For this reason, the calibration factors of LaCoste and Romberg meters do not change perceptibly with time. This eliminates any need for frequent checks of calibration.

### MAINTAINING THE GRAVITY METER

Although the instrument is extremely reliable and trouble free, occasionally minor adjustments might need to be made in the field. It is probably a good practice to run a routine check about once a month under normal usage.

The levels are checked as follows:

1. Check the Displacement Sensitivity. (Adjustment of the long level. The long level is the level that is parallel to the longest dimension on top of the gravity meter.)
  - (A) Level meter.
  - (B) Unclamp beam.
  - (C) Turn on reading lights.
  - (D) Observe position of crosshair.
  - (E) Turn dial (measuring screw) to locate upper and lower stops (or motion limits of crosshair).
  - (F) Position crosshair by means of the measuring screw about one scale division above lower stop.
  - (G) Turn measuring screw dial clockwise one revolution, which is ten units on the counter, or approximately 1 milligal.
  - (H) Observe the number of units the crosshair moves in the eyepiece.
  - (I) The correct displacement sensitivity should be approximately one eyepiece division for one counter unit.

If the displacement sensitivity check shows a sensitivity of approximately 9 to 11 eyepiece divisions for 10 counter units, then a long level adjustment is unnecessary.

If the displacement sensitivity is low, it means a slight loss in reading accuracy. (The crosshair responds to a dial change but the amount is less; consequently, it is more difficult to detect crosshair response.)

Theoretically, if the displacement sensitivity is high, more accurate readings should be obtainable but the response is slower. Actually on certain specialized surveys, the displacement sensitivity has been doubled to increase reading accuracy. At some point of increased

sensitivity, however, the meter becomes unstable and cannot be nulled.

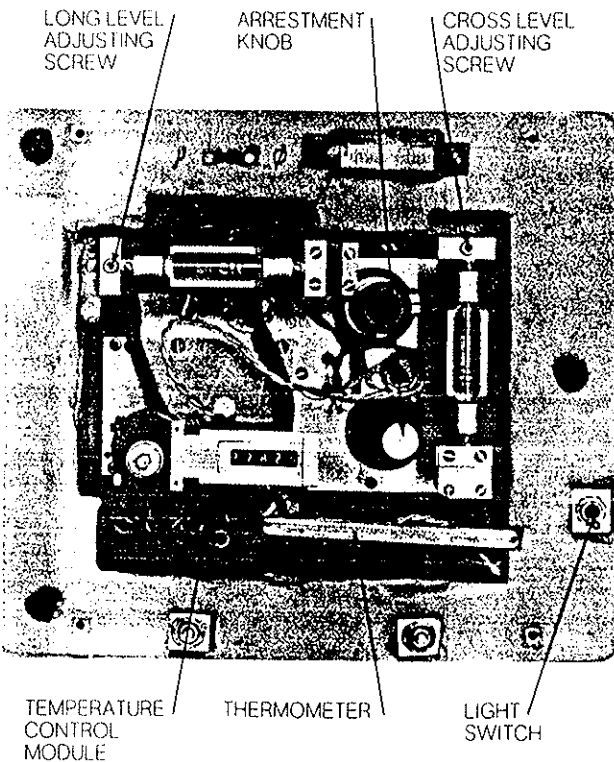

Meter with Top and Insulation Removed

2. Setting the Displacement Sensitivity (Long Level). Adjustment to both the long level and cross level may be made externally through holes in the black phenolic top of the gravity meter located near the end of each level. These access holes are covered by small black anodized plates. Loosen the small screw holding the plate and rotate the plate to give access to an Allen-head cap screw directly below. After determining the proper level position for the gravity meter as described below, adjust the level by turning the cap screw with the furnished Allen wrench to bring the level bubble into a centered position. After a final recheck replace the cover plates.

Some older models do not have externally adjustable levels and it will then be necessary to remove the phenolic top from the gravity meter to make level adjustments. When this is the case, remove the dial and top, then insert the eyepiece lens in the telescope tube adapter to observe the

crosshair. A special wrench is supplied for making adjustments to the level nuts.

With either method, adjustments should be made in small increments. Usually about one fourth to one half bubble division is all that will be required.

- (A) If the sensitivity is low, the gravity meter should be tilted so that the right end of the meter is lowered. (Bubble moves away from eyepiece stalk.) A check should be made as outlined in "1" above to determine whether the amount tilted was the approximate amount needed. If so, adjust the level so the bubble is in the center position. The sensitivity should then be rechecked as outlined in "1" above. (Although this is a simple adjustment it is not done frequently and therefore it may take several attempts to correctly set the sensitivity.)

**Be sure the cross level is in the level position when the gravity meter is being read in this sensitivity check and adjustment.**

- (B) If the sensitivity is high, the gravity meter is tilted so the right end of the meter with one leveling screw is raised. (Bubble moves toward eyepiece stalk.) Then the same procedure outlined in Step (A) is followed.
3. Locating the correct reading line.
    - (A) Level meter carefully.
    - (B) Set crosshair on reading line as specified for the meter. If this is not known, choose a position approximately midway between the stops.
    - (C) Keeping the cross-level in the level position, tilt the long level one division, first in one direction and then in the other, and record the eyepiece reading. Repeat several times to be sure of the reading.
    - (D) If the crosshair in the eyepiece moves upscale approximately the same for each tilt, then the chosen reading line is correct.
    - (E) If the crosshair moves up appreciably more when the meter is tilted to lower the end with the single leveling screw, the assumed reading line is too high. If the crosshair goes down for this tilt, the assumed reading line is too low.
    - (F) If the correct reading line was not chosen in Step (B), then the crosshair should be shifted one eyepiece division with the dial

(either up or down depending on the results of Step (E) ) and the tilting procedure is repeated.

The reading line should be checked whenever the long level (displacement sensitivity) has been adjusted.

NOTE: After tilting the meter off-level wait approximately 30 seconds for the beam to come to rest.

#### 4. The Cross Level.

The correct setting of the cross level is the setting which gives the minimum effect due to tilt. It can be checked by moving the cross level one division off-level, first in one direction and then in the other. If the cross level setting is correct, the crosshair should move upscale approximately an equal amount for each tilt. Be sure the long level is in the level position each time the meter is read. If the cross level is out of adjustment proceed as follows:

- (A) Level meter so that the cross level is off center approximately half of a division in the direction which gave the lower eyepiece reading in the above experiment.
- (B) Using the level wrench supplied with the meter, adjust the cross level so the bubble is in the center position and repeat the setting procedure described above.

On those models where it is necessary to remove the phenolic top, the adjustment is made by adjusting the nuts on the level vial mounting flat with the special wrench supplied. A very small nut rotation is usually all that is required. When the top is replaced and the dial is installed, remember to phase the numbers on the dial with the corresponding last numbers on the counter.

It has been assumed that only minor adjustments were necessary to bring the levels into proper adjustment. In this case the steps 1 through 4 are in the normal order. However, if one or both of the levels is off several bubble divisions, then after adjustment of each level the other level should be rechecked.

#### 5. Temperature Control Circuitry.

All components associated with the temperature control system are solid state. A temperature-sensing thermistor bridge operates an amplifier and power transistor to control the current to the heating element. The components are of high quality with a substantial safety factor. A circuit diagram is included in the manual.

If the meter fails to heat properly the trouble is most likely to be caused by a broken wire in the power cable, a bad plug connection, improper battery voltage

(polarity also must be observed), or bad connections to the battery.

NOTE: Poor field data are sometimes caused by inadequate temperature control due to faulty electrical connections between the battery and gravity meter. The most likely place for a faulty connection is in the Mark connector on the side of the gravity meter case. The sockets on the Mark connector sometimes lose enough tension in field use to give unreliable electronic contacts. The remedy is to disconnect the Mark connector from the gravity meter and carefully crimp the contacts to give more pressure on the mating pins.

If the trouble is not found in these areas, the instrument will probably have to be returned to the LaCoste and Romberg laboratory.

The operator should familiarize himself with the best operating temperature for the meter and be alert for detectable changes in the temperature. Except in extreme weather conditions when the outside temperature can affect the stem of the thermometer, there should be no visible change in the thermometer reading.

#### 6. The Reading Light and Level Lights.

The reading light in the Model G gravity meter is a #330 14-volt aircraft lamp. The level lights, directly beneath the level vials, are #327 28-volt aircraft lamps. Since the level lamps are operating on less than one half of their rated voltage, they will have an extremely long life.

Although the reading lamp operates at 12 volts, it too has a very long life. (Normally 2 spare reading lamps are furnished). Access to this lamp is obtained by removing the aluminum disc on the side of the meter. To remove the reading lamp loosen the screw securing the copper contact strip; then the lamp is easily removed from the bakelite tube. It will be necessary to adjust the new lamp for optimum brightness and clarity. Be sure the screw holding the lamp is well secured after replacing or adjusting the reading lamp.

NOTE: As a matter of good field practice the level lights and reading light should be turned off between readings to prolong lamp life, reduce drift, avoid excessive power consumption and excessive heat around the level vials.

#### 7. The Battery

Detailed charging instructions and other pertinent information applying to the specific battery supplied with this meter are included in the manual.

8. General Information.

- (A) Temperature Control. About two hours are required to heat the meter to its operating temperature. Since the meter must be stabilized at this temperature for at least two additional hours prior to obtaining gravity readings, it is recommended that the meter be maintained at its operating temperature constantly. This is a good field practice even though the meter is used intermittently. To keep the meter at operating temperatures when not in use, it can be connected to the eliminator portion of the battery charger-eliminator.
- (B) Arrestment of clamping mechanism. The beam in the gravity meter should be clamped between readings to avoid any variations in spring length which might result in errors due to hysteresis.
- (C) Sticking or hanging of the moving system. Although much improvement has been made over the years, occasionally the beam (crosshair) will stick on the bottom, top, or sometimes both stops. Usually a gentle tap on the case will free the beam. Although this can be somewhat annoying, the accuracy is not normally affected. Generally, sticking does not occur until the meter has been in use for several years. It is necessary to return the meter to our laboratory for cleaning of the stops to eliminate the sticking.
- (D) Frequently customers ask how often a meter should be returned to the laboratory for a routine cleaning and check out. Probably the best criteria for this are the results being obtained. If good gravity ties are being obtained and no major problems are obvious, then there is no need to return the meter to the laboratory for a check up. When meters are sent in for servicing it is suggested that the battery, battery charger, and all cables be included. Usually about a week to ten days is required for a general cleaning and check out.
- (E) Gravity meter unstable. On a few occasions the long level on a gravity meter has gotten out of adjustment enough so that the meter becomes unstable. When this condition exists it is difficult or impossible to balance the beam on the reading line. The crosshair cannot be controlled with the measuring screw. The operator can duplicate this condition by tilting the meter two or three bubble divisions in the sensitive direction (see section—Setting the Displacement Sensitivity)

and observing the behavior; the correction of course is to adjust the long level as outlined earlier.

- (F) If only a small portion of the screw is used for the survey work, it is recommended that the micrometer screw be turned through its entire range at least once every three months. This procedure is necessary to assure that the micrometer screw has an even distribution of the lubricants and to avoid any hardening of the lubricants which in turn will make the gravity meter inoperative.

**CAUTION — MAKE SURE THAT THE PROPER INSTRUCTIONS ARE USED FOR THE BATTERY AND CHARGER-ELIMINATOR FURNISHED WITH THIS GRAVITY METER.**

**GEL/CELL BATTERY CHARGER-ELIMINATOR UNIT**

Description of Gel/Cell Battery Charger-Eliminator Unit

The Gel/Cell battery eliminator-charger unit is designed to operate on line voltage in the range of 115 or 230 volts  $\pm 10\%$ , 47-200 Hz, **AC only**.

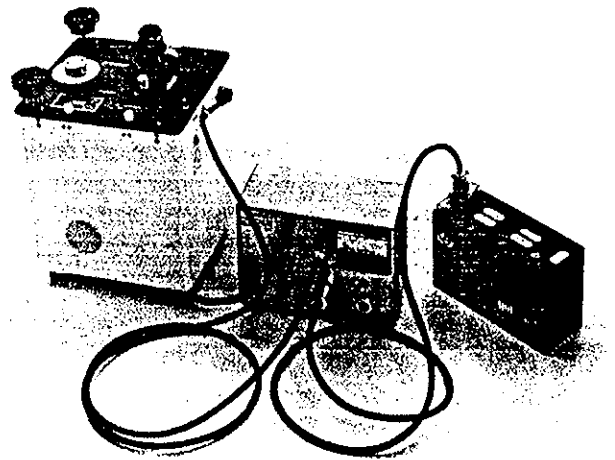

Charging Battery with Gravity Meter Connected

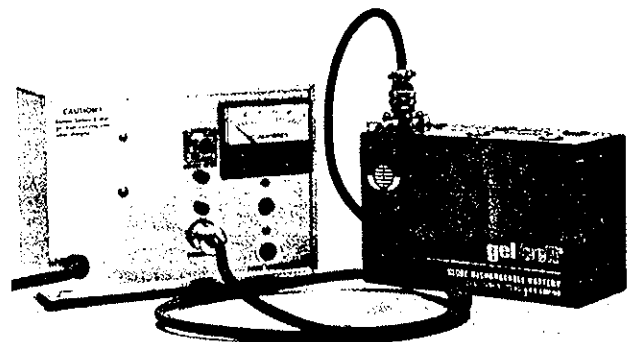

Charging Battery Only



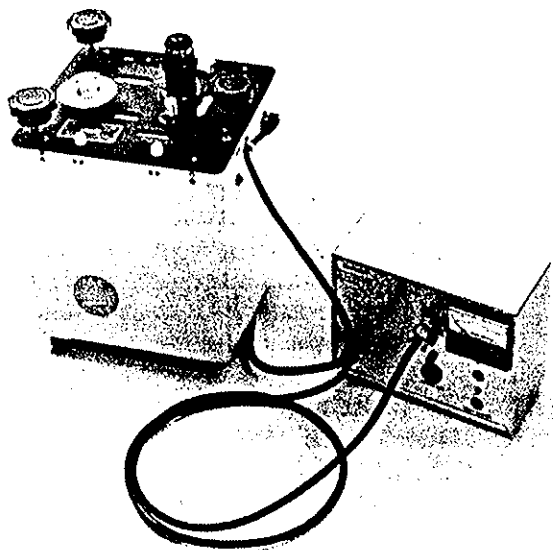

Meter In Storage

As the name indicates, the unit serves two purposes:

- (1) Provide operating power when the gravity meter is stored "on heat" for an extended period of time; or
- (2) Recharge the battery to its operating capacity

#### Operation of the Gel/Cell Battery Charger-Eliminator Unit

##### 1. Battery Eliminator

Put the input voltage switch in the correct position: in the 115-volt position if the power source is between 100-130 volts or in the 230-volt position if the power source is between 205-255 volts. Connect the line cord to the power source.

If the line voltage is not known, always place the input voltage switch in the 230-volt position to avoid accidentally tripping a circuit breaker. If the line voltage is in the lower range and the switch in the higher position, the pilot light will glow dimly, or not at all.

Connect the power cable from the gravity meter to the gravity meter connector on the Charger-Eliminator unit. The gravity meter will be maintained at operating temperature. An LED indicates when the heating current is on and off.

##### 2. Battery Charger

**Remove the battery and charger from the carrying case for ventilation.**

Put the input voltage switch in the correct position as explained in the Battery Eliminator section. Connect the line cord to the power source.

Connect the charger cable to the battery and to the charger unit. The proper charging voltage and current is automatically supplied to the battery.

A battery which is not fully charged will initially draw about 0.7 ampere. As the battery approaches a fully charged condition, the current will gradually decrease until the current is about 0.1 ampere, at which time the charger automatically switches to a "float voltage", and the LED charge indicator turns off.

The gravity meter can be connected to the battery charger-eliminator to maintain its operating temperature while a battery is being charged. If the gravity meter is "cold" and the eliminator portion of the battery charger-eliminator is being used as a power source to bring the gravity meter up to its operating temperature; do not attempt to charge a battery until the gravity meter has started thermostating. In this manner, the gravity meter will reach its operating temperature faster and the battery will be charged before the gravity meter is stabilized.

The ammeter of the battery charger-eliminator will fluctuate slightly with the heat cycle of the gravity meter when the gravity meter is connected to the eliminator and a battery is being charged.

#### Trouble Shooting the Gel/Cell Battery Charger-Eliminator Unit

The unit is designed and constructed so that with reasonable care a long service life can be expected. All components are used well within their safe working limits.

The eliminator circuit is protected by current limiting within the voltage regulator circuitry and the charger circuit is protected by a 1.5 amp circuit breaker. If the pilot light is on and there is no charging output voltage, the circuit breaker has probably tripped.

A second circuit breaker has been placed in series with the power line input. If line voltage is present and the neon power indicator is not on, this circuit breaker has probably tripped. Another possibility is that the 115/230 volts switch could be in the wrong position. These circuit breakers are accessible by removing the bottom plate of the charger eliminator unit.

For safety, the unit is supplied with a three wire power cable. The third wire should be grounded when the unit is in use.

Important: Because of the design characteristics of the unit it would be impractical for the user to attempt to replace components in the event of a malfunction. Do not make any internal adjustments. If a unit must be repaired, it should be returned to LaCoste & Romberg, Inc.

#### Information about Gel/Cell Batteries

Globe Gel/Cell batteries are designed for long, trouble-free service. Sealed construction permits them to be operated, stored or charged in any position. The following operating tips will help obtain the maximum amount of satisfaction from their use:

1. Gel/Cell batteries are fully charged when shipped, but they should be recharged before using.
2. Recharge only with the supplied LaCoste & Romberg, Inc. charger. Other chargers may reduce battery life.
3. The battery charger-eliminator unit has an automatic cut off; however, if a meter is to be in storage for longer than two or three days, remove the battery after it is fully charged.
4. Recharge as soon as possible after each use; store fully charged.
5. Preferred storage temperature is 70°F or below. The battery should be fully charged before storing and recharged at six month intervals. Higher temperatures require more frequent charging. Storage at temperatures about 100°C should be avoided.
6. Eventually the battery will gradually lose its capacity to fully recharge. When operating time after a full charge is no longer satisfactory, it is time to replace the battery.
7. A charging period of 12-20 hours is usually sufficient to bring a completely discharged battery to full charge.

#### Recharge Instructions

General: The open circuit voltage of the Gel/Cell battery is approximately 12.7 volts. The voltage is sometimes lower for a severely discharged battery and sometimes higher for a battery that has just been taken off charge; but in all instances it should adjust to about 12.7 volts after a period of time.

The initial charge current that flows into the Model 1245 battery is limited to about 0.7 ampere. As the battery begins to accept charge, its voltage will rise. Normal end of charge voltage is 14.4 volts (measured while the charge current is flowing). Voltage is only one of two indicators that must be used to determine whether a battery is fully recharged. The other is current. A battery is not fully charged until the current, at 14.4 volts, drops to

an approximate final current of 100 ma.

When the current into the battery, at 14.4 volts, reaches this value, the charger automatically drops the voltage to the "float voltage" of about 13.5 volts. If the battery is held at 14.4 volts continuously, battery life will be significantly reduced because of over charge.

A float voltage is considered to be 13.5 volts. The term "float voltage" should not be confused with the term "trickle charge." "Float voltage" refers to the condition where the charging voltage is held constant and the charging current is free to vary. In contrast, "trickle charge" refers to the condition where the charging current is held constant and the voltage is free to vary. It is important to obtain the maximum number of recharge cycles of the battery.

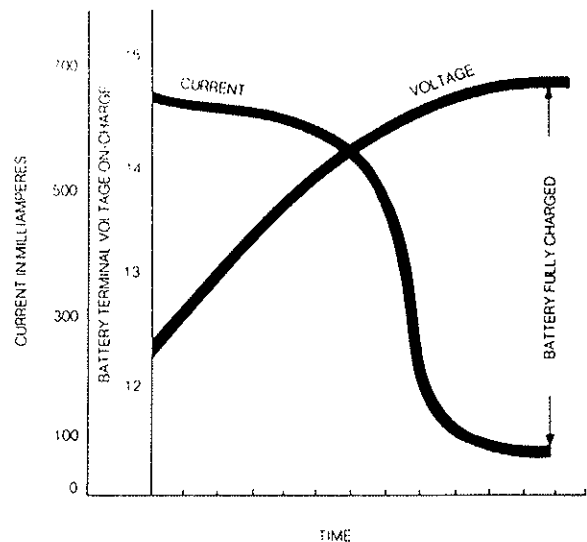

Recharging Curve for GC 1245

#### Battery Life

Using this "cyclic use" method of recharge, 200 to 400 or more complete "full charge/full discharge" cycles are possible. Of course, if the battery is only slightly discharged during each cycle, instead of being totally discharged, literally thousands of cycles of operation are possible.

#### Ratings

Gel/Cell batteries are rated at the 20 hour rate. This means a 4.5 A.H. battery, for example, will put out .225 amps for 20 hours (20 hours x .225 amperes = 4.5 ampere-hours). This does not mean, however, that a 4.5 ampere hour battery will put out 4.5 amperes for 1 hour. A 4.5 A.H. battery will actually put out about 3.7 amperes for 1 hour. Therefore, the capacity of a 4.5 A.H. battery at

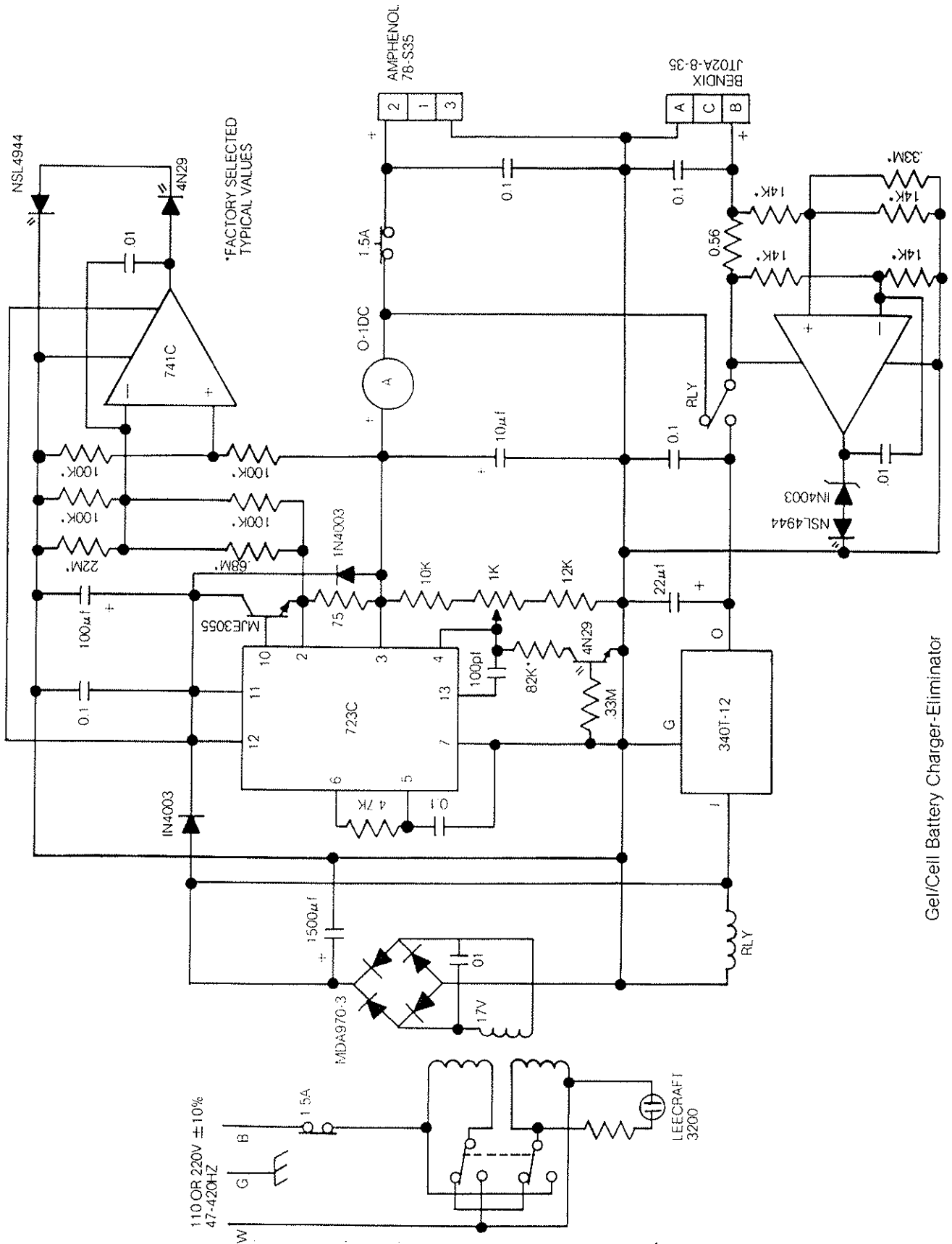

\*FACTORY SELECTED  
TYPICAL VALUES

Gel/Cell Battery Charger-Eliminator

LACOSTE & ROMBERG, INC.  
MODEL G AND MODEL D  
GRAVITY METERS

APPLICABLE TO ALL MODEL G AND MODEL  
D GRAVITY METERS

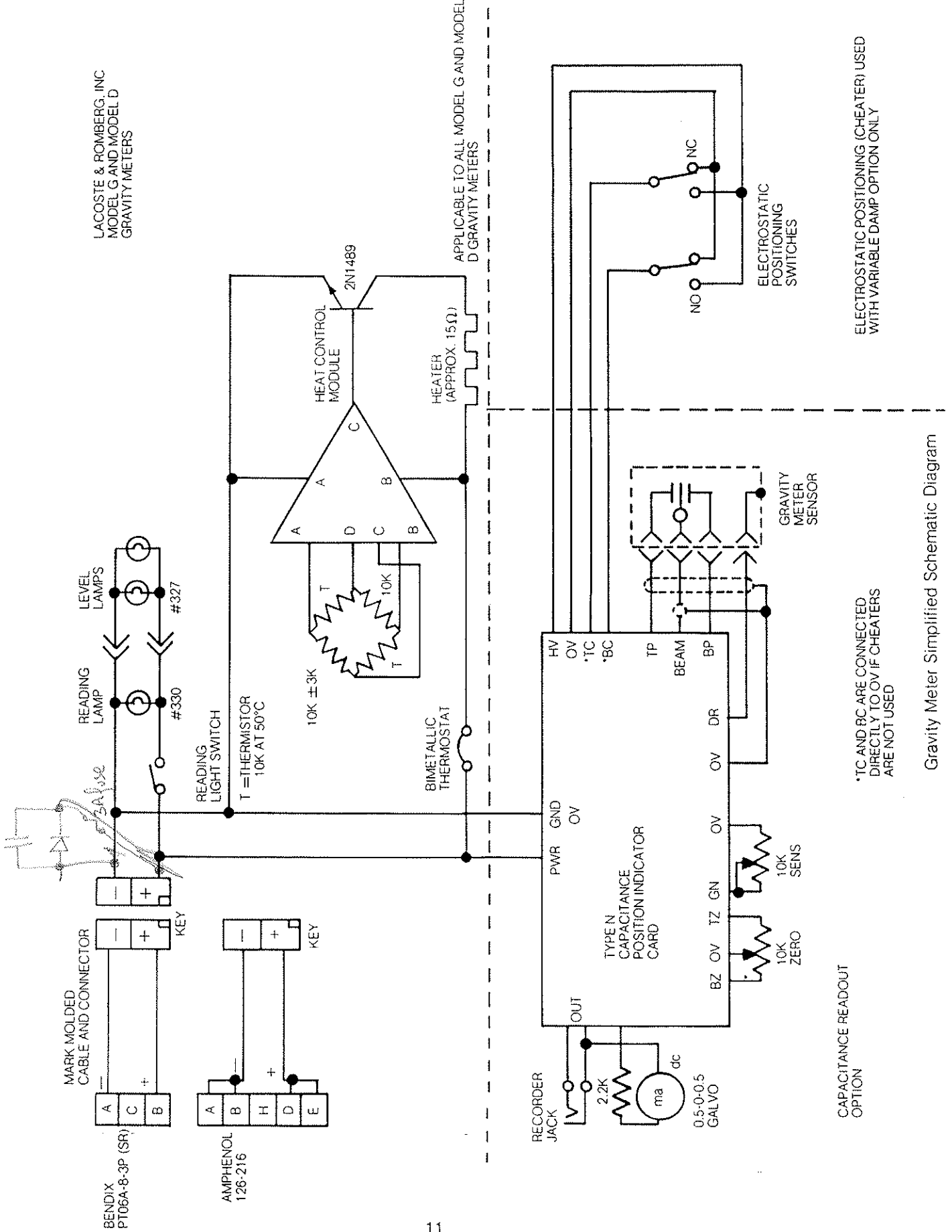

\*TC AND BC ARE CONNECTED  
DIRECTLY TO OV IF CHEATERS  
ARE NOT USED

CAPACITANCE READOUT  
OPTION

ELECTROSTATIC POSITIONING  
SWITCHES  
USED  
WITH VARIABLE DAMP OPTION ONLY

Gravity Meter Simplified Schematic Diagram

the 1 hour rate would be 3.7 A.H.

It is typical for all battery systems that as the rate of discharge increases, the total capacity available from the battery decreases. A new Gel/Cell battery has an initial capacity of 80-90% of its nominal value up to 150-200 cycles. After 200 cycles or so, the battery capacity slowly falls. End of battery life occurs when the battery capacity is no longer suitable for a specific application. Batteries that are not recharged soon after discharge, or are stored in a discharged state, may appear to be "open-circuited" when an attempt is made to recharge them or they will accept far less than normal current. When this condition is encountered, leave the charger connected to the battery. After a period of time the battery will begin to accept normal current or will accept larger and larger amounts of current until the normal current level is reached. On future recharges, the battery will behave normally unless it is again stored in a discharged state.

### BRAKING DEVICE

The following drawing is an exploded diagram of the device for braking (or offering a slight resistance to) the dial rotation. The drawing illustrates the procedure for assembling the components of the device.

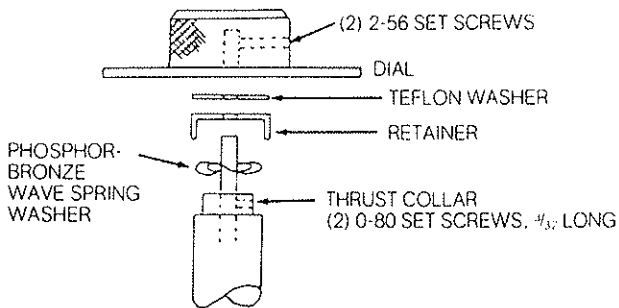

Braking Device (Gear Box Stalk)

Due to friction of the micrometer screw, gears, and rubber seals there is sometimes a tendency for the dial to kick back or have a small backward movement. This

can be a bit troublesome when trying to null very accurately with the micrometer screw dial.

Adjustment of the braking devices is made by loosening the 2-Set Screws in the dial and simply pressing the dial downward until the right "feel" is obtained for each particular gravity meter.

Several adjustments might be required.

When the dial is adjusted, be sure to phase the number on the dial with the corresponding last number on the counter.

### RETURNING GRAVITY METER FOR REPAIRS

If the LaCoste & Romberg, Inc. gravity meter can not be repaired in the field and/or when the observed gravity data is poor, the instrument should be returned to the laboratory for repairs. Be certain that LaCoste & Romberg, Inc. personnel know what the problem is. This information can be sent by letter, telephoned in or given in a list of problems placed in the gravity meter case when the instrument is returned.

For domestic users, ship the gravity meter directly to LaCoste & Romberg, Inc.  
6606 N. Lamar  
Austin, Texas

Foreign customers should do two things. First a "Foreign Shippers Declaration," see exhibit 1, should be included with the shipping documents and one copy of this declaration should be air mailed to LaCoste & Romberg, Inc. so that the gravity meter can be expedited through U.S. Customs. Second the gravity meter should be shipped as follows:

LaCoste & Romberg, Inc.  
c/o Harle Services, Inc.  
Customs Brokers  
P.O. Box 60164 AMF  
Intercontinental Airport  
Houston, Texas 77060  
USA

All gravity meters should be returned to the laboratory via air freight.

## SPECIAL INSTRUCTION FOR CAPICITANCE READOUT OPTION (CPI ELECTRONIC READOUT)

### General Information

To obtain a gravity reading electronically, the gravity meter is leveled, the arrestment knob turned counter clockwise to free the mass and the dial turned in the proper direction to center the needle on the galvanometer.

The inexperienced operator should first read the instruction manual and practice reading the gravity meter by the eyepiece optics as outlined in the manual to familiarize himself with the gravity meter.

It will be noted that the galvanometer does not show the full motion of the crosshair as observed in the eyepiece. The galvanometer will only indicate 2 or 3 eyepiece divisions each side of zero. The relationship between one galvanometer division and one eyepiece scale division when on or near the reading line is about one to one.

After a little practice the operator should be able to take gravity readings quite rapidly and accurately with the electronic reading method.

In the event of a component failure the gravity meter can be read with the standard optical system.

### Technical Information

1. Important: Always observe polarity when connecting meter to a 12-volt d.c. power source.

2. Procedure for adjusting electronics:
  - (A) Be sure levels are in proper adjustment.
  - (B) Null Crosshair. (Be sure proper reading line is being used.)
  - (C) Adjust galvanometer zero to reading line (center of galvanometer). Turning the zero potentiometer clockwise causes the galvanometer needle to move to the right.
  - (D) Turn dial clockwise one tenth milligal (10 small dial units). Observe position of galvanometer needle. Turn sensitivity adjustment potentiometer ("sens") until galvanometer reads one major division for one tenth milligal dial change.

A clockwise adjustment will increase sensitivity.

Repeat steps (B)-(D) several times if necessary.

3. In the event of failure in the electronic readout, trouble shooting will probably be limited to checking for broken wires, low battery voltage or similar minor problems. If failure does occur, the gravity meter will probably need to be returned to the manufacturer for repair.

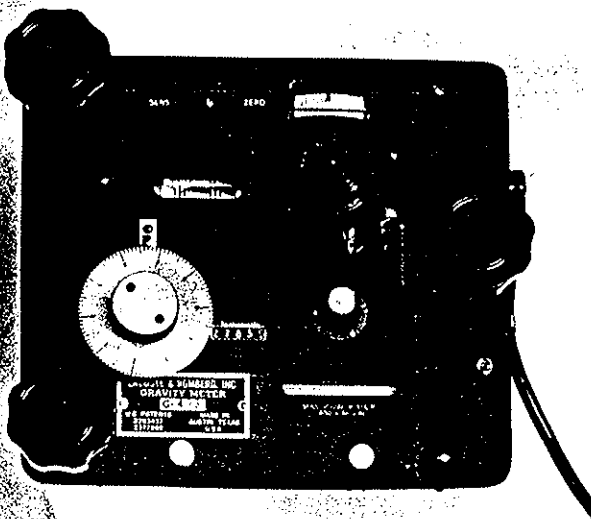

Standard G-Meter with Electronic Readout



Connection to G-Meter

4. The output of the CPI is available from the miniature phone jack on the side of the meter. This beam position output is derived from a separate amplifier on newer systems, but is in parallel with the galvanometer on earlier models. Except on the newest Type NCPI system, the output is differential; the common-mode voltage to battery minus is 4-5 volts. (In the older type cards, permanent damage to the CPI card may result if the output is grounded or tied to any device not having a differential input.) Type NCPI cards are identified with the decal placed just below the output jack on the side of the gravity meter. The use of a differential input on equipment driven by the CPI

output will prevent ground loops, and is, therefore, recommended. The jack bushing is tied directly to the battery minus.

With the CPI gain adjusted for one galvanometer division per eyepiece division, the output is about 0.33 volts per eyepiece division. The output impedance of the Type NCPI cards is less than 100 ohms, but the output should be loaded with a minimum impedance of 500 ohms.

5. When recording data from the CPI output, the gravity meter may be powered by the battery, the battery eliminator, or by a regulated 12 volt dc power source. Observe polarity if using a 12-volt source.

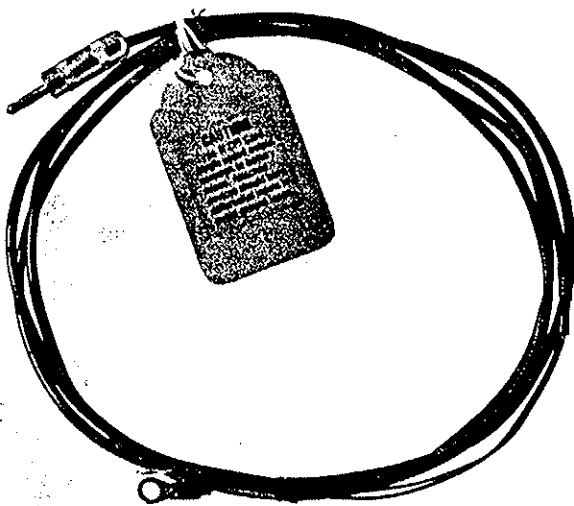

Recorder Cable

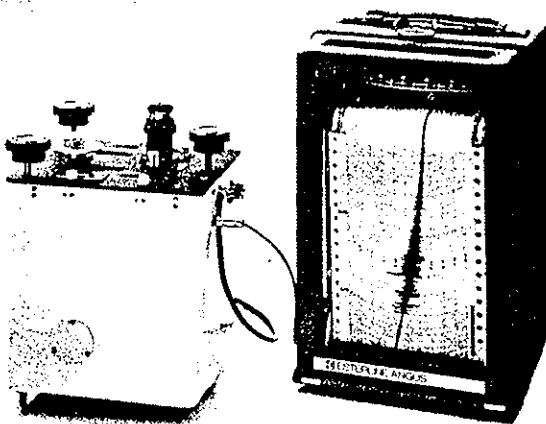

Electronic Readout Connection to Recorder Option

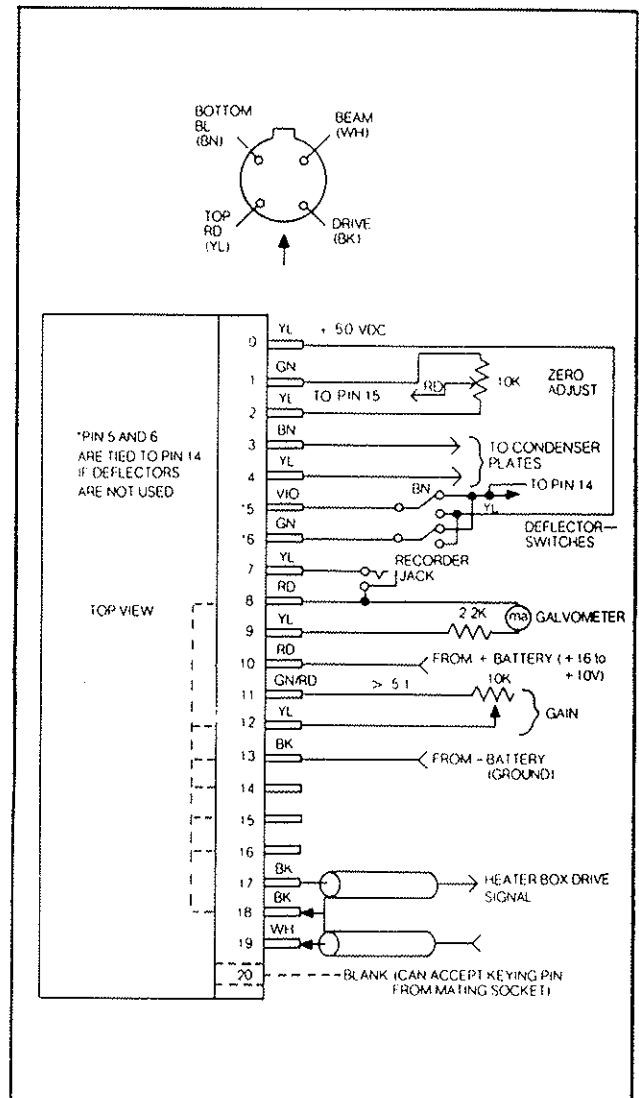

Connection Diagram for CPI Circuit

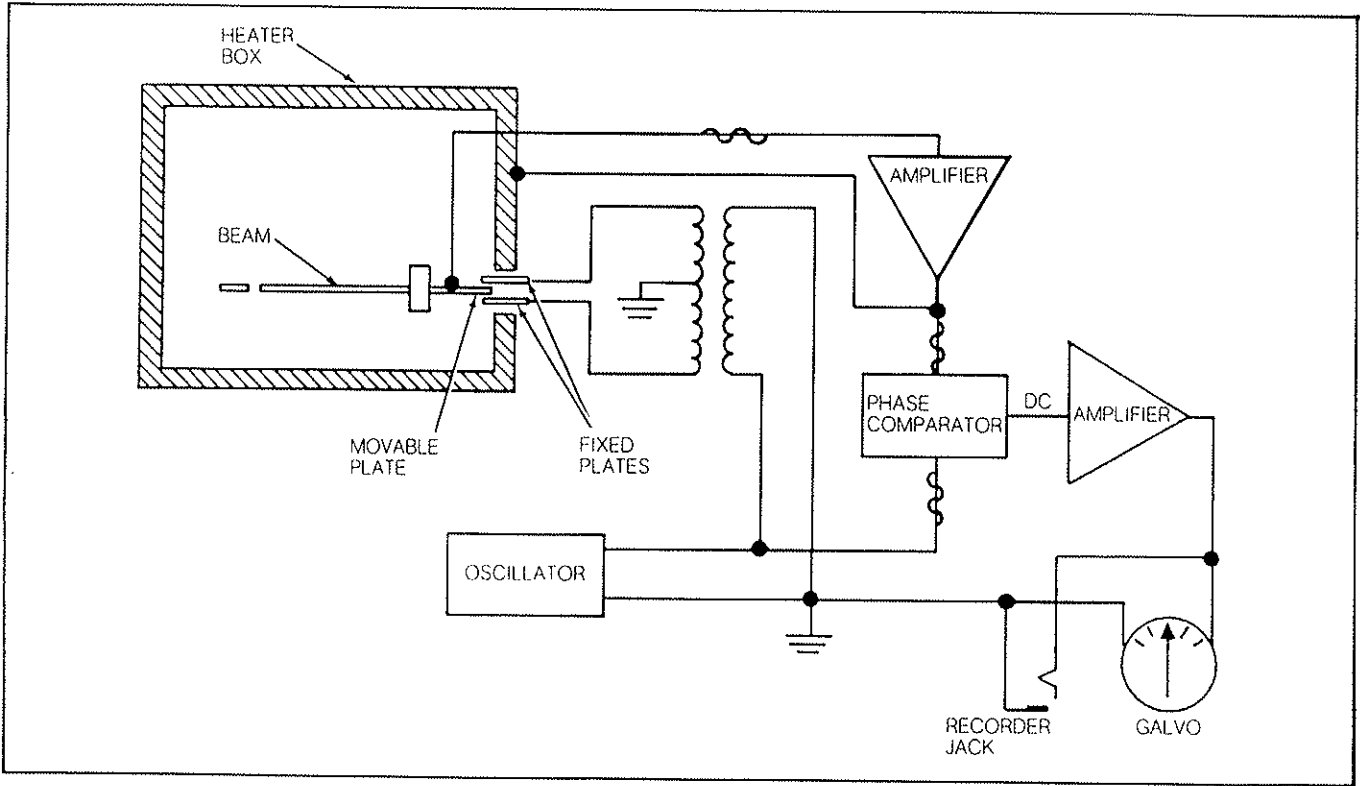

Simplified Diagram of Capacitance Readout System



FOREIGN SHIPPERS DECLARATION  
COVERING THE RETURN OF UNITED STATES MERCHANDISE

Required: When value of goods exceeds \$1,000.00 UScy.

I, \_\_\_\_\_ DECLARE THAT THE ARTICLES SPECIFIED HEREIN ARE, TO THE BEST OF MY KNOWLEDGE AND BELIEF, THE GROWTH, PRODUCE OR MANUFACTURE OF THE UNITED STATES. THAT THEY WERE EXPORTED FROM THE UNITED STATES FROM THE PORT OF \_\_\_\_\_ ON OR ABOUT \_\_\_\_\_ THAT THEY ARE RETURNED WITHOUT HAVING BEEN ADVANCED IN VALUE OR IMPROVED IN CONDITION BY ANY PROCESS OF MANUFACTURE OR OTHER MEANS.

Marks	Qty	Model No.	Description	S/N	Value in U.S. \$
-------	-----	-----------	-------------	-----	---------------------

SHIPPED VIA \_\_\_\_\_ DATE \_\_\_\_\_

DATE: \_\_\_\_\_ SIGNATURE \_\_\_\_\_

TITLE \_\_\_\_\_

ADDRESS \_\_\_\_\_

U.S. Customs regulations, Sec 10,1, revised as of October 1957 provides that shipments of returned U.S. Goods valued over \$1,000.00 requires foreign shippers declaration for FREE ENTRY into the United States.

Customer \_\_\_\_\_

## **GUARANTEE**

All LaCoste & Romberg gravity meters are guaranteed for a period of 1 year after delivery. At the Purchaser's request, LaCoste & Romberg will make all necessary adjustments, repairs and parts replacements. All parts will become the property of LaCoste & Romberg on an exchange basis. This guarantee will not apply if such adjustments, repair or parts replacement are required because of accident, neglect, misuse, operation on improper power, transportation or causes other than ordinary use. All necessary adjustments, repair or parts replacement will be made at no charge to the Purchaser provided that the Purchaser pays all transportation cost to and from the LaCoste & Romberg, Inc. laboratory in Austin, Texas. The period of the guarantee is extended by the length of time that the gravity meter is in transit and in the laboratory for repairs.

The foregoing guarantee is in lieu of all other guarantees expressed or implied, and all obligations or liabilities on the part of LaCoste & Romberg, Inc. for damages, including but not limited to consequential damages arising out of or in connection with the use or performance of the meter.

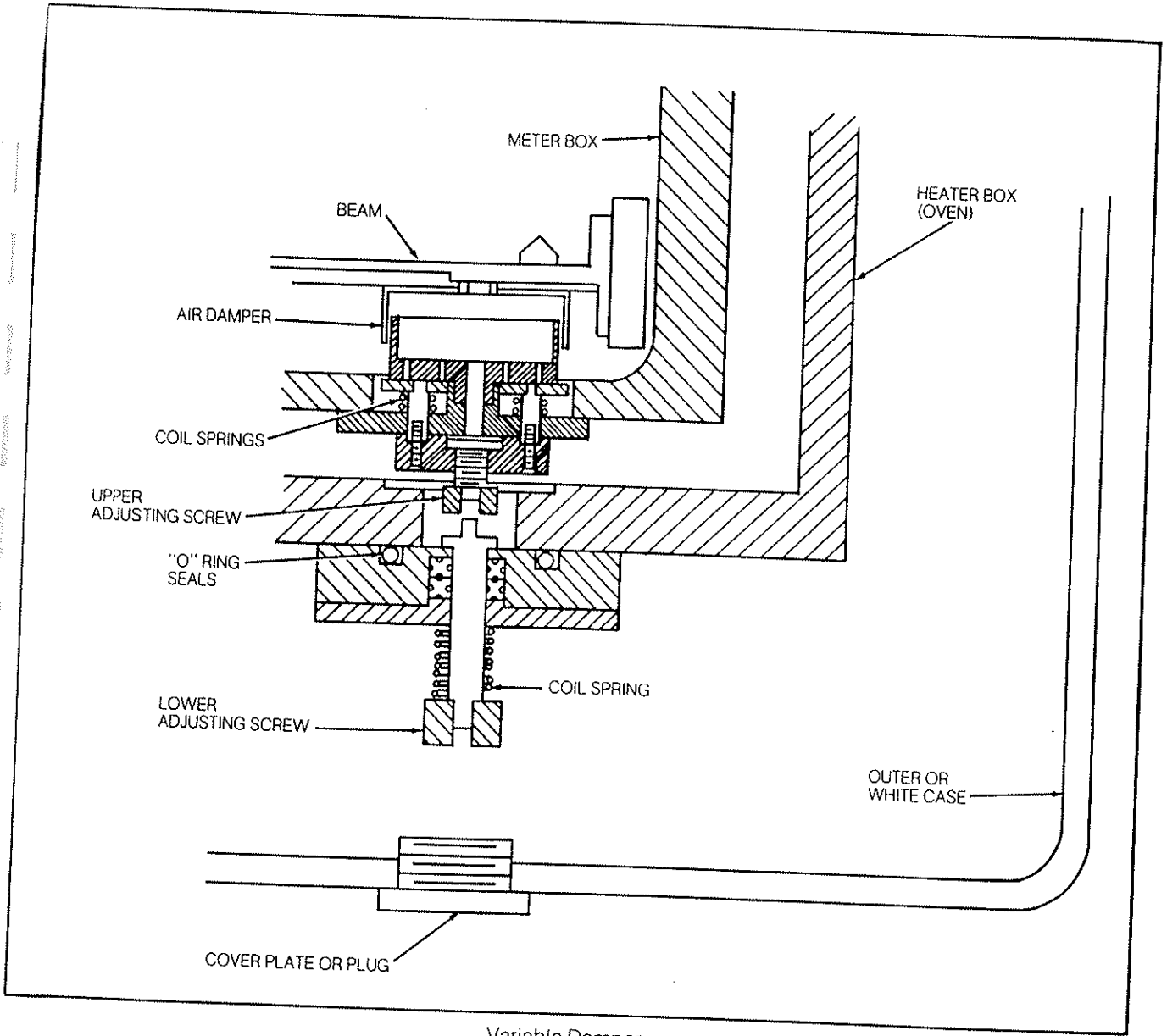

Variable Damper