

TxII Transmitter

5000W-2400V-10A

Instruction Manual



**860 boul. de la Chaudière, suite 200
Québec (Qc), Canada, G1X 4B7
Tel.: +1 (418) 877-4249
Fax: +1 (418) 877-4054
E-Mail: gdd@gdd.ca
Web site: www.gdd.ca**

Visit our web site at:

WWW.GDD.CA

To:

- Discover GDD's new products.
- Download the latest version of the Instruction Manual.
- Comment on or ask questions about products.

TABLE OF CONTENTS

1. INTRODUCTION	4
2. SAFETY	4
3. TRANSMITTER DESCRIPTION.....	5
3.1 EQUIPMENT LIST.....	5
3.2 TRANSMITTER COMPONENTS	5
3.2.1 <i>Output Terminals</i>	5
3.2.2 <i>Power Cable</i>	7
3.2.3 <i>1.0X / 1.5X MODE Switch</i>	7
3.2.4 <i>Status LEDs</i>	7
3.2.5 <i>Master-Slave Interface</i>	7
3.2.6 <i>Current Display</i>	7
3.2.7 <i>Serial Number</i>	7
3.2.8 <i>Ohmmeter and Wattmeter Display</i>	7
3.2.9 <i>High Voltage Indicator</i>	8
3.2.10 <i>Turbo Switch</i>	8
3.2.11 <i>Cancel O.L.P. Switch (open loop protection)</i>	8
3.2.12 <i>Warning LEDs</i>	8
3.2.13 <i>Voltage Selector</i>	9
3.2.14 <i>Circuit Breaker</i>	9
3.2.15 <i>Power switch: ON / OFF</i>	9
3.2.16 <i>Time Base / DC Selector (optional)</i>	9
3.2.17 <i>Vent Pipes</i>	9
4. TRANSMITTER OPERATION	10
4.1 STEPS TO FOLLOW	10
4.2 OUTPUT POWER	10
5. MASTER / SLAVE MODE.....	11
6. TROUBLESHOOTING	13
7. TECHNICAL HELP	15
8. SPECIFICATIONS.....	16
9. GLOSSARY	17

1. INTRODUCTION

The GDD 5000W IP Transmitter, model TxII, is used for time-domain induced polarization survey. Its transmission cycle is 2 seconds ON, 2 seconds OFF. Other timings are available upon request. It is sturdy and can operate in extreme climatic conditions (-40 °C to 65 °C).

The GDD 5000W-2400V-10A IP Transmitter can be powered directly from a 240 VAC power source, such as a portable regulated generator. The TxII transmits up to 10 A in a highly conductive ground or sends up to 2400V in a resistive ground for a total power of 5000W.

2. SAFETY

The GDD TxII is easy to use. Although, it automatically stops within microseconds if a short circuit occurs or if the circuit becomes open. However, for the safety of the users, we strongly recommend to always wear electrically insulated shoes and gloves when operating the transmitter.

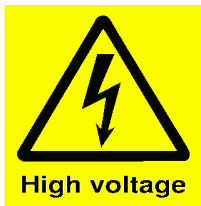

Safety hints:



Wear electrically insulated shoes. They should be approved by certified organization (CSA, ANSI) i.e. marked with the logo: 



Wear electrically insulated gloves rated class 1 (7,5 kV).

3. TRANSMITTER DESCRIPTION

3.1 Equipment list

When receiving a GDD 5000W-2400V-10A IP Transmitter, model TxII, ensure that it contains the following elements:

- One (1) TxII Transmitter built in a transportation box from Pelican.
- One (1) 1.87 meter 20A power cable extension.
- One (1) 0.34 meter 20/30A cable adaptor.
- One (1) Instruction manual.
- One (1) Blue carrying case.

Optional

- 2, 25 or 50 meters electrical extension cord
- GDD yellow Master-Slave cable

Do not hesitate to communicate with GDD Instrumentation Inc. if needed.

3.2 Transmitter components

In this section, the TxII components from the control panel are shown, named and explained (see figure I on the next page).

3.2.1 **Output Terminals**

This is where the wires from the electrodes are connected. Press the button over each terminal to insert wires. Be careful, the terminals can reach up to 2400V.

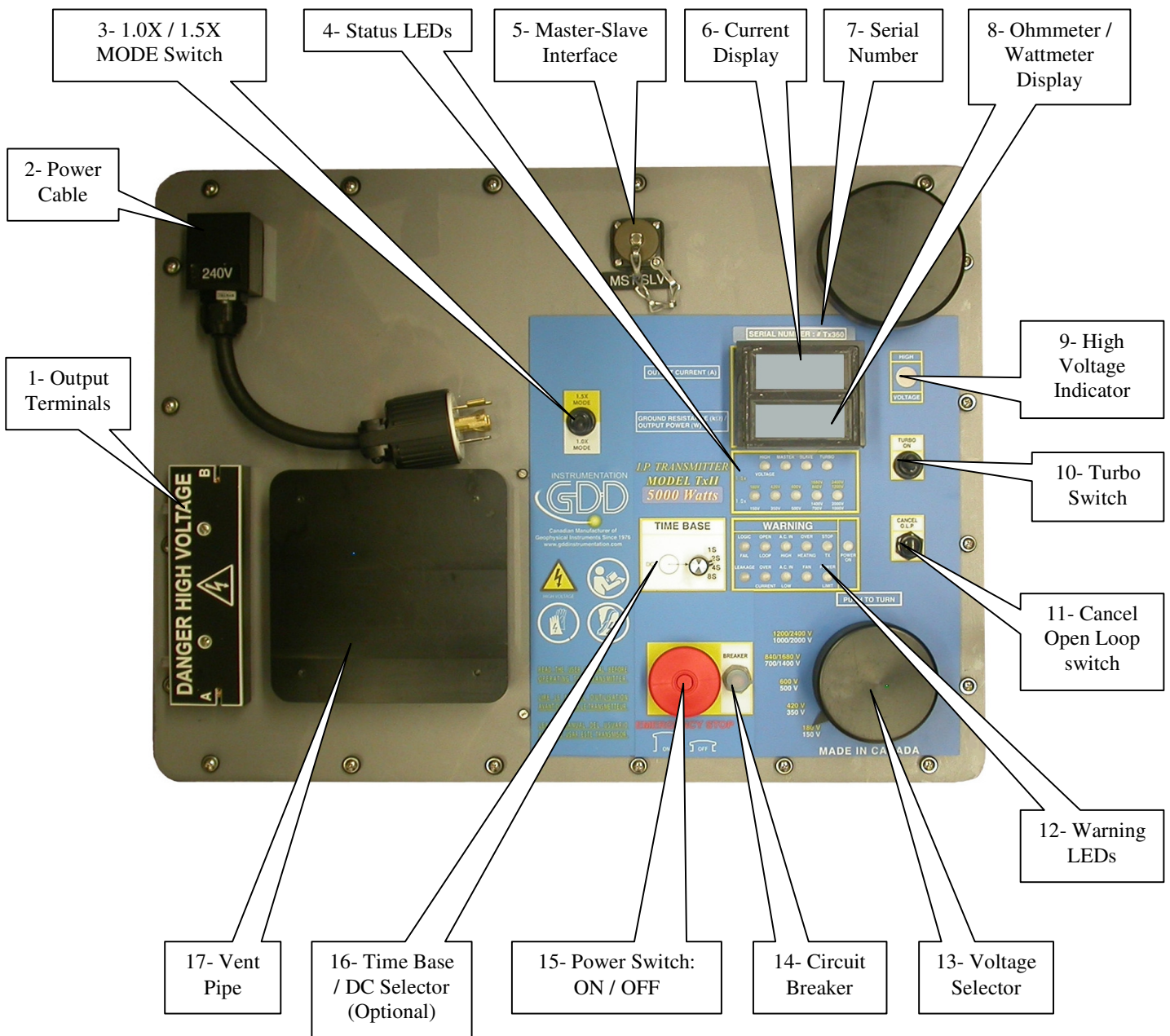

Figure 1 : Control panel

3.2.2 Power Cable

The termination of the power cable can be plugged into any 220-240 VAC / 50-60 Hz voltage source. Please check transmitter's nameplate for specificity.

3.2.3 1.0X / 1.5X MODE Switch

There are two different modes: 1.0x and 1.5x. When the 1.5x mode is selected, the output voltage will be 120 % higher and the power 150% higher compared to the 1.0x mode.

3.2.4 Status LEDs

The red lights indicate the following elements:

HIGH VOLTAGE: This LED turns ON and OFF to indicate the presence of high voltage on the output terminals, allowing the operator to follow the TxII transmission cycle.

MASTER: This LED lights up for two reasons: when the transmitter is in stand-alone or in MASTER configuration.

SLAVE: This LED lights up when the transmitter is in SLAVE configuration.

TURBO: This LED turns on when the turbo mode is activated, that is to say when the output voltage changes from 700V / 840V to 1400V / 1680V or from 1000V / 1200V to 2000V / 2400V.

The lighted 150, 350, 500, 700/1400 or 1000/2000 red LEDs indicate the rated voltage present at the output while transmitting. These values increase 120 % when the selector is on the 1.5X mode.

3.2.5 Master-Slave Interface

The Master-Slave interface allows to link two transmitters with a synchronization cable (optional yellow Master-Slave cable) to increase the total output power and the output voltage of the system.

3.2.6 Current Display

Displays the output current and refresh this value four times per second. The first and the last reading may overlap the off cycle and have to be rejected.

3.2.7 Serial Number

Each instrument has its own serial number to identify it.

3.2.8 Ohmmeter and Wattmeter Display

GROUND RESISTANCE: It displays the ground resistance when the generator is plugged and the

transmitter is powered *OFF*. The value shown is the contact resistance in kilo-ohms (x1000Ω).

OUTPUT POWER: When the transmitter is transmitting, the output power expressed in Watt is indicated instead of the contact resistance.

3.2.9 High Voltage Indicator

This LED turns ON and OFF to indicate the presence of high voltage on the output terminals, allowing the operator to follow the TxII transmission cycle.

3.2.10 Turbo Switch

All voltage scales above 1200V can be set with the *Turbo* switch. This switch allows to reach the 1400 V / 1680V or 2000V / 2400V scales while the voltage selector is on the 700V / 840V or 1000V / 1200V position.

NOTE: It may take up to 4 seconds before the *Turbo* turns ON or OFF.

3.2.11 Cancel O.L.P. Switch (open loop protection)

The GDD TxII has an internal open loop protection circuit to prevent direct electric shock to the operator. This protection trigs when the electrodes are not connected to the output terminals or when the current is less than 30 mA.

NOTE: If the ground has a very high resistivity, the open loop protection could disrupt the transmission of signal. To temporarily cancel the O.L.P. turn the TxII *OFF*, press and hold the *Cancel O.L.P.* button and turn the TxII *ON*.

3.2.12 Warning LEDs

The red lights indicate the following problems:

LOGIC FAIL: Caused by an internal electronic failure.

LEAKAGE: A synchronization trouble caused a leakage current.

OPEN LOOP: This alarm trigs when there is infinite resistance between the two output terminals (the circuit is open) or when the output current is less than 30 mA (highly resistive ground).

OVER CURRENT: This alarm trigs when the current limit is exceeded. The current limit is set to 10 A in normal modes and 5 A in DC mode.

A.C. IN HIGH: High (≥ 290 VAC) or irregular voltage from the generator. An unregulated generator can trig this alarm. The power transformer may overheat.

A.C. IN LOW: Low (≤ 170 VAC) or irregular voltage from the generator. An unregulated generator can trig this alarm.

OVERHEATING: The internal temperature of the transmitter is too high ($\geq 85^{\circ}\text{C}$). Leave the transmitter in this state until the LED turns off to let it cool off.

FAN: The *FAN* indicator lights up when the fan is running. The fan starts automatically to cool down the transmitter when the temperature inside the transmitter is higher than 65°C .

STOP TX: Indicates that the transmitter stopped transmitting. This LED lights up with the warning LEDs.

POWER LIMIT: Indicates that the power limit has been exceeded. This limit is set to 5000W.

POWER ON: Indicates that the transmitter is powered on.

3.2.13 Voltage Selector

To set the output voltage, press and turn this selector to the right position. Pressing down this knob will stop the current transmission. The available output voltages are:

- 1.0x mode: 150V, 350V, 500V, 700V, 1000V, 1400V and 2000V.
- 1.5x mode: 180V, 420V, 600V, 840V, 1200V, 1680V and 2400V.

3.2.14 Circuit Breaker

There is a built-in circuit breaker to protect the instrument from overloading.

3.2.15 Power switch: ON / OFF

Press to turn off the transmitter and pull to turn on the unit.

3.2.16 Time Base / DC Selector (optional)

There are two different possible time base selectors. These optional time base selectors allow the following modes: 1s, 2s, 4s, 8s or 0.5s, 1s, 2s, 4s. The DC option is also available, allowing the transmitter to work as a DC voltage source.

3.2.17 Vent Pipes

There are two vent pipes on the control panel. The *FAN* warning light indicates if the fan is running. Make sure that the airflow is not being obstructed by any object (e.g.: leaves, snow, etc.).

4. TRANSMITTER OPERATION

4.1 Steps to follow

Here are the basic steps for a stand-alone operation of the TxII:

1. Make sure that the TxII is turned *OFF*.
2. Drive the electrodes into the ground and connect them to the output terminals with insulated wires.
3. Start the generator.
4. Put the voltage selector to the lowest voltage scale (150V), put the 1.0X / 1.5X switch to the 1.0x mode and turn the transmitter *ON*.
5. Increase the output voltage to increase the output power. It is not necessary to turn off the transmitter to change the voltage scale or select a different time base (optional). The 1.5x mode allows reaching an intermediate output power. Note that the transmitter will automatically stop if you try to transmit more than 5000W. In this case, select a lower voltage scale and turn the transmitter *OFF* and *ON* again to reset the STOP TX alarm.

IMPORTANT:

- Turn *OFF* the transmitter only when the “HIGH VOLTAGE” LED is off, that is to say in the *OFF* time of the cycle or when the STOP TX light is triggered.
- Turn *OFF* the transmitter before shutting down the generator.

4.2 Output Power

If a generator more powerful than 5000W is used, the output power will be limited to 5000W by the TxII. If the generator used cannot deliver up to 5000W, such as a 700W generator, the output power will be limited by the generator.

5. MASTER / SLAVE MODE

Here are the basic steps for a Master/Slave operation of the TxII:

1. Connect the yellow synchronization cable (Master/Slave) to the transmitters. The Master/Slave cable terminations are different: one is labeled *MASTER* and the other one *SLAVE*. The transmitter is *MASTER* or *SLAVE* according to the termination of the cable connected on his interface. The *MASTER* and *SLAVE* LEDs indicate the mode of each transmitter. (see figure 2, yellow line)
2. Connect an insulated wire between the terminal (A) of one transmitter and the terminal (B) of the other one. (see figure 2, blue line)
3. Connect the two power cables from the transmitters to the generator. (see figure 2, red lines)
4. Drive the electrodes into the ground and connect them to the unused terminals (A) and (B) by using insulated wires. (see figure 2, blue lines)

- Power cables
- Yellow Master-Slave cable
- Wires

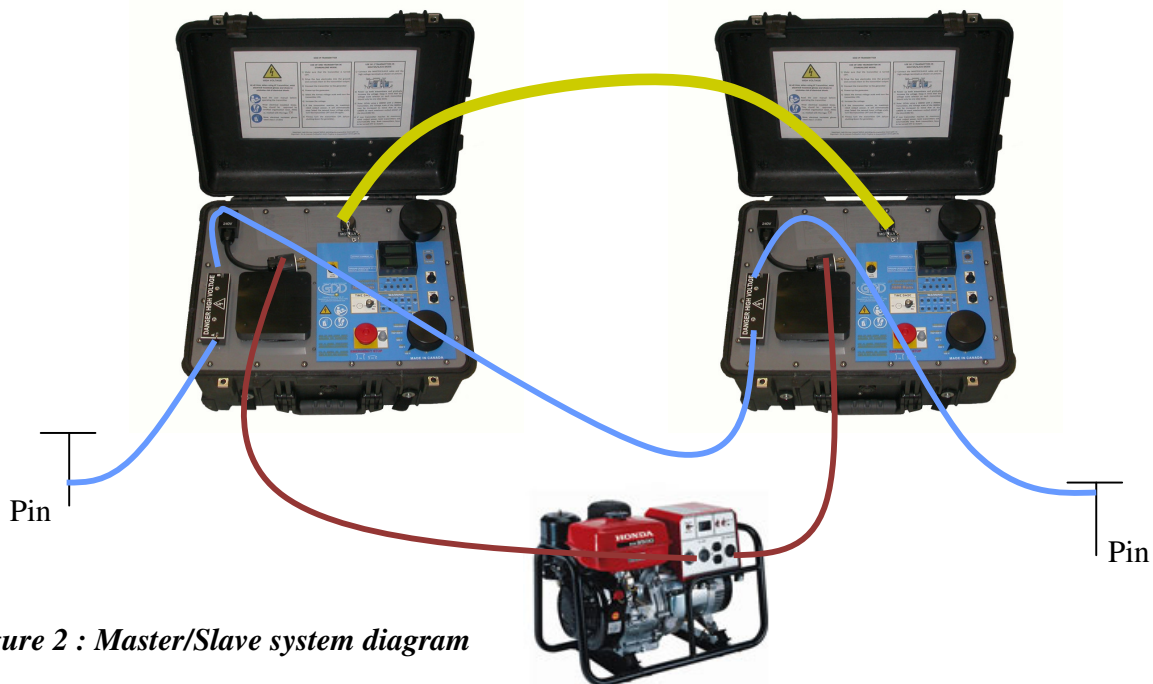

Figure 2 : Master/Slave system diagram

5. Make sure that the voltage selector is at the minimum scale (150V) on both transmitters.
6. Put the 1.0X / 1.5X switch to the 1.0x mode
7. Turn on both transmitters.
8. Gradually increase the output voltages until the transmitters stop.
9. Reduce the output voltage of one transmitter by one step with the voltage selector.
10. Turn OFF and ON the Master transmitter.

NOTES

- If the Master/Slave cable is not connected, the transmitter will work in stand-alone mode.
- Both transmitters can be master or slave.
- It is possible to reach 4800V with two transmitters in a Master/Slave system.
- The current displayed on both transmitters should be the same (± 0.1 A).
- The selected voltage scale on both transmitters should not be more than one step different, in order to have power transmitted by both transmitters as close as possible.

6. TROUBLESHOOTING

With a good understanding of the transmitting circuit and a little logic, most of the problems that will happen with the TxII can often be solved.

1- Nothing seems to work

The ON LED doesn't light up and the display remains blank: check if the power source (generator) is working properly. Check also the power cable and the extension cord. The breaker might also be triggered.

2- The ON LED lights up but the TxII does not transmit

First, check if the voltage selector is not pressed down. Then check which warning LEDs also light up:

LOGIC FAIL: Indicates that an internal electronic failure occurred. Turn OFF and ON the TxII. If it doesn't work, move the TxII away from the current electrodes.

LEAKAGE: Turn OFF and ON the TxII. If it doesn't work, move the TxII away from the current electrodes.

OPEN LOOP: Can be caused by a cut wire or by highly resistive ground. In such a case, you can bypass the open loop protection with the Cancel O.L.P. switch.

OVER CURRENT: The output current is too high. Reduce the output voltage or pull out a bit the electrodes from the ground.

A.C. IN (HIGH or LOW): Indicates that the power source (generator) is defective. The supply voltage must be stable and between 170 VAC and 290 VAC. Try to transmit less power with the TxII or change for another kind of generator.

WARNING: Always use a regulated generator. An unregulated generator could damage the instrument which would then not be covered by the warranty.

OVERHEATING: Indicates that the internal temperature of the TxII is too high. Don't turn OFF the TxII but leave it in this state to let the fan running and cool off the instrument.

POWER LIMIT: Reduce the output voltage.

STOP TX: This LED lights up when one of the previous problems is detected.

3- The TxII works well but the output power is very low

First, check if it is possible to increase the voltage. Every time you increase the voltage scale by one step, the output power is approximately doubled. It is therefore possible to send 3000W at a given scale (e.g.: 6000 mA at 500V) but the TxII will stop transmitting on the next higher scale (e.g.: 8400 mA at 700V) since it would try to transmit around 5880W. In such a case, try the 1.5x mode at the 500V scale in order to have an intermediate output power, e.g. around 4300W (7200 mA at 600V). You can also raise or lower the electrodes in the ground in order to alter the overall resistivity of the circuit. This could allow you to transmit 5000W at 700V.

4- Ground with very high resistivity

If the ground is highly resistive, it is possible that the output current is too low even at the maximum voltage. In such a case, you have to improve the electrode contact with the ground.

Here are a few suggestions:

- Move the electrodes to get a better contact;
- Double (or more) the number of electrodes;
- Water the electrodes (with salt water if available).

5- Noise, Bad signal (Receiver)

The noise is an undesired interference or a disturbance that affects the signal.

The source of noise may be a second IP or EM transmitter operating in the area; the interference zone may be as large as 10 kilometers, depending on the power of the instrument and the system used. If a recurrent signal is received while the transmitter is powered off, this is certainly due to a second transmitter. The receiver could even synchronize with the signal if compatible.

Telluric currents may also cause the noise: they occur naturally near the surface of the earth and concentrate in conductive zones such as overburdens, shale or graphite formation, etc. To continue the survey in spite of telluric currents, one should improve the electrode contacts and increase the output current of the transmitter in order to increase the signal-to-noise ratio.

Finally, the noise may originate from a defective transmitter or receiver. First, check the electrodes, decrease the contact resistance and make sure there is no loose contact. The signal timings of the receiver and the transmitter must be the same. If necessary, take a reading at a precedent station or repeat tests with another receiver or transmitter.

7. TECHNICAL HELP

If you encounter a problem that can't be fixed or that is not described in the troubleshooting section, or for any particular information, do not hesitate to contact **Instrumentation GDD Inc.**

Phone: +1 (418) 877-4249
Fax: +1 (418) 877-4054
Toll free line (for Canada): 1 (877) 977-4249
E-mail: gdd@gdd.ca / gdd@gddinstrumentation.com

Emergency (out of business hours):

Pierre Gaucher:

Home tel.: (418) 657-5870
Mobile phone: (418) 261-5552

Régis Desbiens:

Home tel.: (418) 658-8539
Mobile phone: (418) 570-3408

Any GDD TxII transmitter that breaks down while under warranty or service will be replaced free of charge upon request for the duration of repairs, subject to instruments availability, except for shipping charges. Although this service is subject to instrument availability, we have been able to honour this commitment until now.

8. SPECIFICATIONS

Size :	TxII-5000W with a blue carrying case: 35 x 52 x 70 cm TxII-5000W only: 26 x 45 x 55 cm
Weight :	TxII-5000W with a blue carrying case: ~ 56kg TxII-5000W only: ~40 kg
Operating Temperature :	-40 °C to 65 °C (-40 °F to 150 °F)
Time Base:	2 s ON+, 2 s OFF, 2 s ON- Optional: 1, 2, 4 or 8 s 0.5, 1, 2 or 4 s DC
Output current :	0.030 A to 10 A (normal operation) 0.0 A to 10 A (cancel open loop) Maximum of 5 A in DC mode
Rated Output Voltage :	150V to 2400V Up to 4800V in a master/slave configuration
LCD Display :	<ul style="list-style-type: none">▪ Output current, 0.001 A resolution▪ Output power▪ Ground resistance (when the transmitter is turned off)
Power source :	220-240 V / 50-60 Hz

9. GLOSSARY

Induced polarisation (I.P.) is a geophysical technique: an electric current is induced into the ground and the voltage decay is monitored through electrodes to measure its conductivity and chargeability. The GDD TxII is one of the principal components for an I.P. survey system.

Short circuit: Very low resistance connection between two nodes resulting in a fault current.

Transmitting circuit: The whole system associated with the TxII: wires, electrodes, ground and transmitter.

Open circuit: Infinite resistance between two nodes. It is the electrical opposite of a short circuit.

Conductive ground: Ground with a low electrical resistivity. Such grounds are usually associated with thick overburden and water presence (e.g.: swamp).

Resistive ground: Ground with a high electrical resistivity. Such grounds are usually associated with bare rock or sand, with little overburden.